

UHMW Line Shaft Pulleys

Impact-resistant UHMW makes superior line shaft pulleys. Flanges do not fatigue and crack as molded pulleys often do.

One-Piece Design: P/N LSP321620 Long-lasting, rugged pulley.

Split Design: P/N LSP321620S Quickly and easily replace old pulleys with these rugged parts. With the split design, you can install this pulley without the time-consuming removal of the drive shaft.

Split Design with Side Grooves: P/N ESP321620 Provides the same great benefits outlined above, with side grooves for line shaft conveyers with spacers between pulleys.

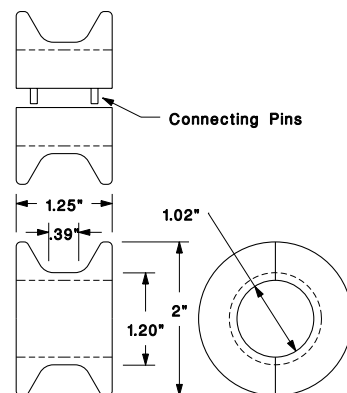

V-Belt Pulleys

UHMW	Belt Size	OD	Pitch Dia.	Width	Stock Bore
110101	A	1.75	1.5	3/4	1/4
110104		2.25	2	3/4	1/4
110108		2.75	2.5	3/4	1/4
110111		3.25	3	3/4	1/4
110112		3.45	3.2	3/4	1/2
110113		3.65	3.4	3/4	1/2
110114		3.85	3.6	3/4	1/2
110115		4.05	3.8	3/4	1/2
110116	B	3.75	3.4	1	1/2
110118		4.15	3.8	1	1/2
110119		4.35	4	1	1/2
110121		4.75	4.4	1	1/2
110122		4.95	4.6	1	1/2
110123		5.15	4.8	1	1/2
110124		5.35	5	1	1/2
110126		5.75	5.4	1	1/2
110127		5.95	5.6	1	1/2

Round Belt Pulleys

UHMW	Belt Dia.	OD	Width	Stock Bore
110128	1/4	1.5	1/2	1/4
110129		2	1/2	1/4
110130		2.5	1/2	1/4
110131		3	1/2	1/2
110132		3.5	1/2	1/2
110133		4	1/2	1/2
110134	3/8	2	5/8	1/4
110135		2.5	5/8	1/4
110136		3	5/8	1/4
110137		3.5	5/8	1/2
110138		4	5/8	1/2
110139	1/2	3	3/4	1/4
110140		3.5	3/4	1/2
110141		4	3/4	1/2
110142		4.5	3/4	1/2
110143		5	3/4	1/2
110144		5.5	3/4	1/2

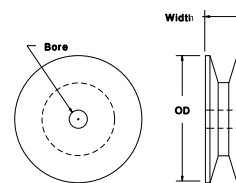

V-BELT PULLEYS

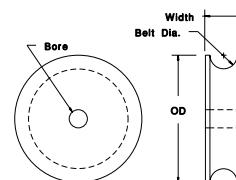

ROUND BELT PULLEYS

Additional Pulleys

Round belt, V-belt and Flat belt pulleys made to order:

- With or without hubs
- Key ways
- Set screws
- Ball bearings
- Multiple grooves

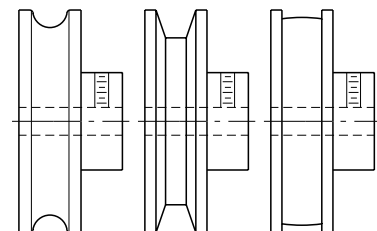

Slideways Successes: Pulleys

The Challenge: An exercise equipment manufacturer needed 2,500 custom pulleys, fast!

The Slideways Solution: We shipped parts in two weeks which not only met their deadline but saved them the cost of injection mold tooling.

